



CC-5B Crusher

From *Recycling Equipment Manufacturing, Inc.*

“THE BEER, SOFT DRINK, AND JUICE DRINKER”



*CRUSH THE CANS...
FRESH WATER RINSE....
LIQUID FLOWS INTO DRAIN...*

Process “line rejects” or “out dated product” and recover aluminum cans and PET Containers for recycling with REM® Series 5B Crushing System. Our Model CC-5B crushes aluminum cans and comes complete with an in-feed conveyor, totally enclosed crushing mechanism, capture tank with drain, and an out-feed conveyor with fresh water rinse.

PROVEN DESIGN

Product is loaded on the in-feed conveyor hopper and is conveyed up into REM's® crusher mechanism where the containers are crushed, with the beverage fluid discharging into the capture tank. The beverage containers are then discharged on the out-feed conveyor belt where they run under a fresh water rinse aiding in the removal of residual beverage fluids. The containers are then discharged into a container, REM® Model CB Can Blower, or a baler. For even greater processing capability, look to our full line of full-beverage destruction systems. To put our model CC-5B to work for you, call **1-800-745-4736**.



CC-5B Series Crushers

A Leader in Recycling Equipment Since 1978

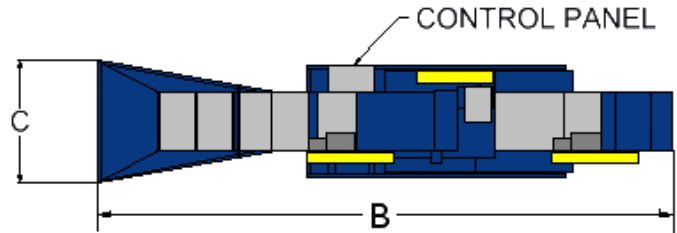
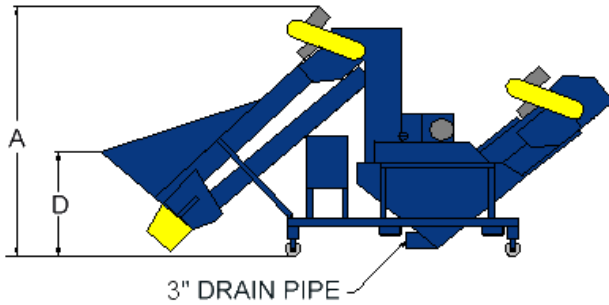

Features:

- Second generation field-proven design for high volume, low maintenance, and easy service
- Enclosed tail pulley cover with external take-ups for correct belt tracking and tension
- Low in-feed hopper for easy loading/visual inspection
- Enclosed belt and chain guards for user protection
- Fresh water rinse on out feed conveyor
- Processes up to 600 cases of aluminum cans per hour.

Specifications:

- All steel unitized construction
- PVC-150 conveyor belting with vulcanized cleats and Flexco 125 Megalloy Lacing
- 8" diameter head pulley, and 6" diameter crowned tail pulley
- 6" industrial steel casters
- Enclosed sides and bottom of belt return pan
- 1/2 HP TEFC conveyor motor
- 5 HP TEFC crusher motor

Electrical safety features:

- 240/480 volt, three phase
- Electrical components are UL listed
- NEMA-4 (hose proof) enclosure
- Sequential manual start motor controls
- Main safety fused disconnect
- Individual motor overload/short circuit protection
- Safety interlock on crusher access door

DIMENSIONS:	
Height (A)	8' 4"
Length (B)	16'
Width (C)	3' 8"
Loading height (D)	3' 4"
Weight-approx. (lbs)	2100
Hopper capacity	1/3 cu. yd.
Conveyor:	
Discharge height	4' 5"
Belt width	16"
Cleat size	1-1/2"
Crushing drum:	
16" wide, welded steel cleats	
Density:	
2-4 lbs. per cubic foot for aluminum cans	

Options:

- 240 volt, single phase
- Stainless steel upgrade
- 208, 380, 415, 480, or 575 volt, three phase
- Power cord
- Custom conveyors, hoppers, discharge heights
- Pump for fluid capture tank
- Wash-down duty bearings
- If you don't see it, ask us!

LIMITED ONE YEAR WARRANTY

*All dimensions are nominal +/- 1"

*Specifications subject to change without notice, without incurring responsibility to previous units sold

Recycling Equipment Manufacturing, Inc.

PO Box 310
 Priest River, Idaho USA 83856
 1-800-745-4736
 Office: (208) 448-4736
 E-mail: sales@remfg.com Fax: (208) 448-1786

Sales and Service