



## CC-5B Perf Crusher/Perforator

From *Recycling Equipment Manufacturing, Inc.*

**“THE BEER, SOFT DRINK, AND JUICE DRINKER”**



*CRUSH THE CANS...  
PERFORATE THE PET...  
FRESH WATER RINSE...  
LIQUID FLOWS INTO DRAIN...*

Process “line rejects” or “out dated product” and recover aluminum cans and PET Containers for recycling with REM® Model CC-5B PERF crusher/perforator. It comes complete with an in-feed conveyor, totally enclosed crushing mechanism, capture tank with drain, and an out-feed conveyor with fresh water rinse.

### **PROVEN DESIGN**

Product is loaded on the in-feed conveyor hopper and is conveyed up into REM's® perforator mechanism where the plastic containers are punctured and aluminum cans are flattened, with the beverage fluid discharging into the capture tank. The beverage containers are then discharged on the out-feed conveyor belt where they run under a fresh water rinse aiding in the removal of residual beverage fluids. The containers are then discharged in a container, REM® Model CB Can or PET Bottle Blower, or a baler. For even greater processing capability, look to our MV or HV PERF. To put our model CC-5B PERF to work for you, call **1-800-745-4736**.



# CC-5B Perf

A Leader in Recycling Equipment Since 1978

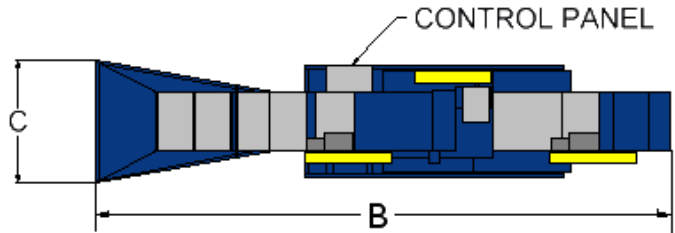
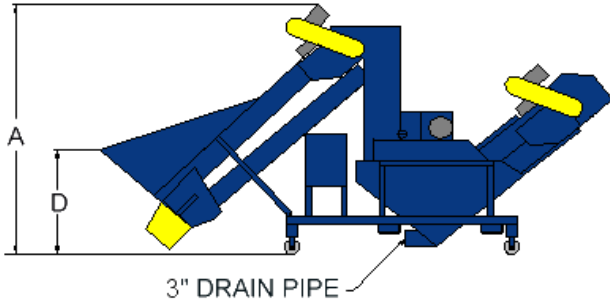

### Features:

- Second generation field-proven design for high volume, low maintenance, and easy service
- Enclosed tail pulley cover with external take-ups for correct belt tracking and tension
- Low in-feed hopper for easy loading/visual inspection
- Enclosed belt and chain guards for user protection
- Fresh water rinse on out feed conveyor
- Processes up to 600 cases of aluminum cans or up to 3000 PET bottles per hour.

### Specifications:

- All steel unitized construction
- PVC-150 conveyor belting with vulcanized cleats and Flexco 125 Megalloy lacing
- 8" diameter head pulley, and 6" diameter crowned tail pulley
- 6" industrial steel casters
- Enclosed sides and bottom of belt return pan
- 1/2 HP TEFC conveyor motor
- 5 HP TEFC crusher motor

### Electrical safety features:

- 240/480 volt, three phase
- Electrical components are UL listed
- NEMA-4 (hose proof) enclosure
- Sequential manual start motor controls
- Main safety fused disconnect
- Individual motor overload/short circuit protection
- Safety interlock on crusher access door

DIMENSIONS:	
Height (A)	8' 4"
Length (B)	16'
Width (C)	4' 2"
Loading height (D)	3' 7"
Weight-approx. (lbs)	2275
Hopper capacity	2/3 cu. yd.
<b>Conveyor:</b>	
Discharge height	4' 5"
Belt width	24"
Cleat size	3"
<b>Crushing drum:</b>	
24" wide, welded steel teeth	
<b>Density:</b>	
25-50% size reduction on PET containers	
2-4 lbs. per cubic foot for aluminum cans	

### Options:

- 220 volt, single phase
- Stainless steel upgrade
- 208, 380, 415, 480, or 575 volt, three phase
- Power cord
- Custom conveyors, hoppers, discharge heights
- Pump for fluid capture tank
- Wash-down duty bearings
- If you don't see it, ask us!

### LIMITED ONE YEAR WARRANTY

\*All dimensions are nominal +/- 1"  
 \*Specifications subject to change without notice, without incurring responsibility to previous units sold

## Recycling Equipment Manufacturing, Inc.

PO Box 310  
 Priest River, Idaho USA 83856  
 1-800-745-4736  
 Office: (208) 448-4736  
 E-mail: sales@remfg.com Fax: (208) 448-1786

Sales and Service