



TCH Series Transfer Conveyors

From *Recycling Equipment Manufacturing, Inc.*

THE TCH SERIES TRANSFER CONVEYOR WITH RECEIVING HOPPER



REM's® Model TCH Transfer Conveyor with Hopper is an affordable alternative to feed small sorting systems such as REM's® Model SC Sorting Conveyors, balers, and shredders. Hoppers are available in square or rectangular designs, with above ground or in-ground pit configurations. The large capacity hopper allows it to be filled with front-end loaders, rotating forks, a REM® Model HDL Hydraulic Container lift or other discharge equipment. Available with an optional air clutch for smooth starts and reduced wear and tear on the drive package. An optional variable speed drive unit is available for adjustable feed rates to compensate for different types of materials.

Built tough for many years of service REM's® TCH is built with a classic slat bed design featuring a reinforced loading area for minimal belt deflection. We offer standard belt widths of 16" through 60" (in 6" increments), standard and custom lengths, inclines, and discharge heights available in many configurations. REM's® drive packages are sized for each particular application making material transfer effortless! Belt materials and variations are matched to your specific requirements. Bolt together modular conveyor sections (for conveyors longer than fifteen feet) allow for your future growth and expansion, simply add a bolt-on section to extend your conveyor length and discharge height.

To put our model TCH Series to work for you, call **1-800-745-4736**.



TCH Series Transfer Conveyors

A Leader in Recycling Equipment Since 1978

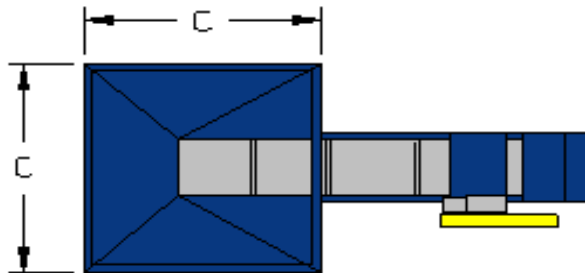
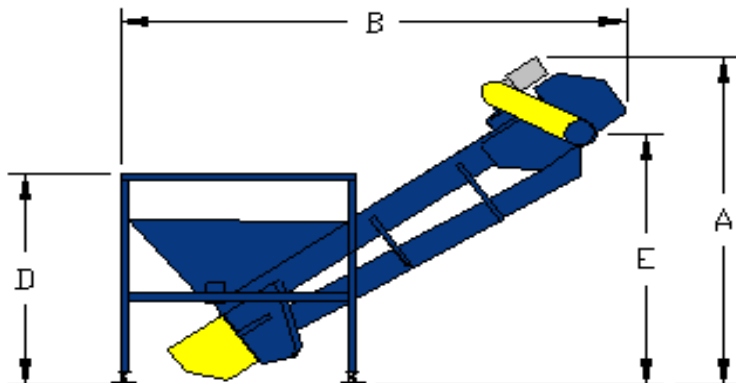

Features:

- Field-proven design for high volume, low maintenance, extended life, and easy service
- Available in standard widths of 16" to 60" in 6" increments
- Enclosed tail pulley cover with external take-ups for correct belt tracking and tension
- Enclosed belt and chain guards for user protection
- Reinforced double slatted loading area to minimize belt deflection

Specifications:

- All-steel unitized construction
- PVC-150 conveyor belting with 3" vulcanized cleats and Flexco 125 Megalloy lacing
- 8" diameter head pulley and 6" diameter crowned tail pulley
- Enclosed sides and bottom of belt return pan
- TEFC motor and drive package engineered to each specific conveyor

Electrical:

- 240/480 volt, three phase
- Electrical components are UL listed
- NEMA-3R (outdoor) enclosure
- Manual starter with thermal overload protection
- Individual motor overload/ short circuit protection

| Dimensions: | TCH-8 | TCH-10 | TCH-15 |
|----------------------|--------|--------|--------|
| Height (A) | 8' | 10' 6" | 13' 6" |
| Length (B) | 11' 9" | 14' | 16' 8" |
| Hopper Width (C) | 6' | | |
| Loading Height (D) | 5' | | |
| Discharge Height (E) | 5' 8" | 7' | 9' 7" |
| Weight approx. (lbs) | 1,900 | 2,000 | 2,150 |

Options:

- 220 volt, single phase
- 208, 380, 415, 480, or 575 volt three phase
- Magnetic head pulley with reversible steel can discharge-chute
- Self cleaning tail pulley
- Custom lengths and widths
- Variable speed-drive
- In floor pit hopper or drop-in hopper
- Air clutch
- Hopper screen to minimize dirt, debris and moisture
- 6" industrial steel casters
- Custom diverter chutes
- If you don't see it, ask us!

LIMITED ONE YEAR WARRANTY

*All dimensions are nominal +/- 1"

*Specifications subject to change without notice, without incurring responsibility to previous units sold

Recycling Equipment Manufacturing, Inc.

PO Box 310 1-800-745-4736
 Priest River, Idaho www.remfg.com Office: (208) 448-4736
 USA 83856 E-mail: sales@remfg.com Fax: (208) 448-1786

Sales and Service